

# Integration Techniques for MMICs and Chip Devices in LTCC Multichip Modules for Radio Frequencies

R. Kulke<sup>\*</sup>, W. Simon<sup>\*</sup>, M. Rittweger<sup>\*</sup>, I. Wolff<sup>\*</sup>,  
S. Baker<sup>+</sup>, R. Powell<sup>+</sup> and M. Harrison<sup>+</sup>

<sup>\*</sup>Institute of Mobile and Satellite Communication Techniques (IMST GmbH)  
Carl-Friedrich-Gauss-Str. 2, D-47475 Kamp-Lintfort, Germany  
Tel: +49-2842-981 214, Fax: +49-2842-981 499, [kulke@imst.de](mailto:kulke@imst.de)  
<sup>+</sup>Marconi Caswell Ltd., Caswell, Towcester, Northamptonshire NN12 8EQ, GB  
Tel: +44-1327-356250, Fax:+44-1327-356775, [sara.baker@gecm.com](mailto:sara.baker@gecm.com)

## Abstract

*One of the goals of the investigations of the two public R&D projects 4M [1] and RAMP [2] is to find out the advantages and limitations of the multilayer LTCC technology in radio frequency applications. In the first steps the material properties have been determined followed by the investigation of different waveguides and passive structures like transitions, feedthroughs and resonators [3,4,5]. In the next step the integration of monolithic microwave integrated circuits (MMIC) and single chip devices has been tested in different configurations. The basic method is to mount a MMIC on the top layer of the LTCC and connect the RF and DC ports with wire bonds to the circuitry of the carrier substrate. An improved electrical performance can be achieved by embedding a chip into a cavity. This will reduce the length and consequently the parasitics of the bond wire. An other advantage could be the reduction of the total substrate thickness for a better heat dissipation of power applications. MMICs on GaAs are expensive and often have a long delivery time. A promising alternative is to design an RF circuit on the LTCC substrate by using single chip devices, which can be mounted in flip-chip technology on the top layer.*

Key words: LTCC, multichip modules (MCM), microwave application, flip-chip

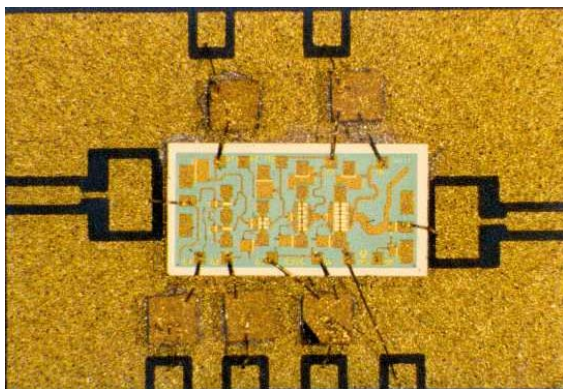
## Introduction

The investigations, which are summarised in this paper, are forced by the demand to develop cost-effective modules for wireless communication applications like point-to-point or point-to-multipoint systems. Worldwide recommendations have made frequency bands up to 50 GHz available. This market is traditionally served by monolithic integrated circuits due to the high technological demands. A one-chip solution is expensive and has a poor yield. Thus, hybrid or so call multichip modules are a cost-effective alternative. However, several integration

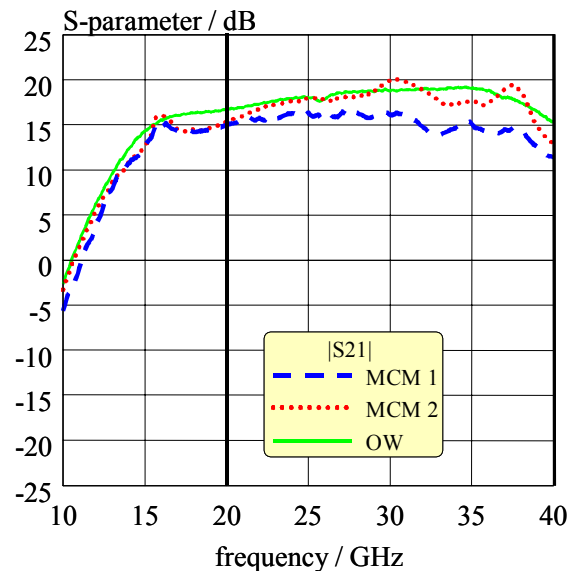
techniques are not yet qualified for microwave applications. A lot of advantages are seen by using multilayer LTCC. This technology has just been established in the telecommunication bands up to a few GHz [7-10]. Beyond these frequencies a number of problems have to be investigated. A comparison of the different technologies for different applications is given in [11]. Especially the integration technique is the focus of this paper. Different amplifiers have been embedded in a LTCC environment and a flip-chip diode has been used in a tripler module. The results are presented in the following chapters.

## Medium power amplifier

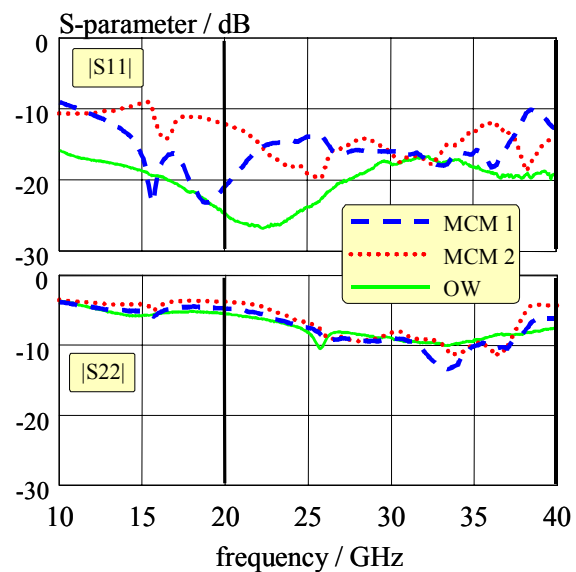
Experiments with these mentioned techniques have been performed in the two R&D projects by the authors. The investigations have started with a medium power amplifier on GaAs from UMS for 20 to 40 GHz. The chip has been fixed with conductive paste on the top ground conductor. Two configurations have been considered: a coplanar waveguide and a microstrip environment. Blocking chip capacitors have been mounted close to the amplifier. RF and DC ports are connected with wire bonds to the coplanar and microstrip lines on LTCC. A step in the line width at the RF ports has been optimised to match the wire bond transition to the 50Ω ports. To improve the heat dissipation of this power amplifier 9 thermal vias filled with silver in connection with a heat spreader on the bottom side of the substrate complete the design of this application. This module has been measured on-wafer up to 40 GHz with GSG-probes with a pitch distance of 200μm. The measured performance in coplanar as well as in microstrip environment agrees with the electrical parameters of the data sheets. With the utilised thermal management no problems with heat-up could be recognized. One of the amplifier circuits in coplanar environment is shown in figure 1.



**Fig. 1:** Photo of the UMS GaAs medium power amplifier on DuPont 951 LTCC with co-fired Fodel™ gold conductor on top of the substrate



**Fig. 2:** Measured gain of the amplifier (OW: on-wafer; MCM1 and MCM2: amplifier on LTCC in CPW environment with different bias conditions)



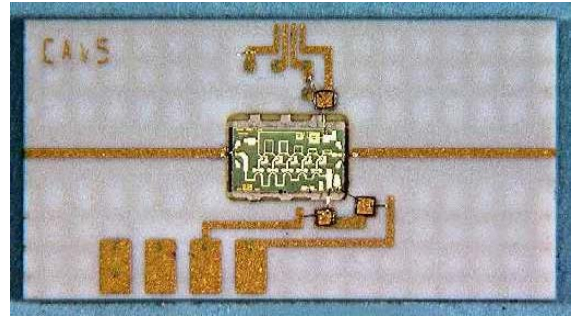
**Fig. 3:** Measured input and output return losses of the UMS amplifier

The amplifier has been measured on-wafer (OW; on the chip in this case) as well as in the coplanar (MCM1 and MCM2) and microstrip environment on LTCC. Since this MMIC has no pre-matching components on the chip, the goal of the investigation was the development of an applicable compensation

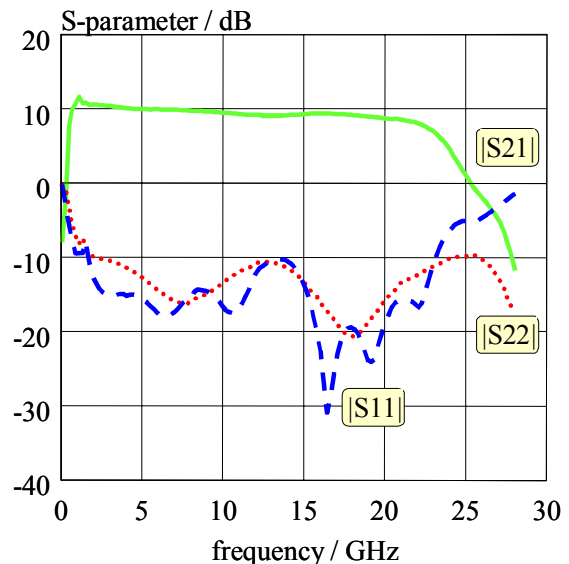
of the parasitics of the transitions from the LTCC board to the chip (especially the inductance of the wire bonds). Figure 2 compares the measured gain of the amplifier, while the on-wafer and the MCM2 configuration have been determined under the same bias conditions. MCM1 has been measured with a drain voltage of 3.5V instead of 3.0V. The results show, that the coplanar line steps on the LTCC are capable to improve the matching to the MMIC. The curves for the gain and the input and output return losses in figure 3 have slightly more ripples compared to the on-wafer measurements. Similar results could be achieved with the same amplifier in the microstrip environment on LTCC.

### Low noise amplifiers in cavities

In a second application two broadband low-noise amplifiers from Caswell Technology have been embedded in cavities of multilayer LTCC substrates. The first LNA P35-5104 is recommended for 2 to 20 GHz applications and has been tested in a microstrip environment. Figure 4 illustrates the module. The second LNA P35-5114 shown in figure 6 is mounted in a cavity in a coplanar environment. This MMIC is made for 20 to 32GHz systems. The LTCC tape A6M from Ferro has been utilised with screen printed gold on the top and bottom of the substrates as well as silver conductors on the inner layers. Wire bonds are used to connect the LNA chips with the microstrip and coplanar lines on the LTCC top layer. Chip capacitors are used in the DC bias supply. The Caswell LNA chips have been designed to compensate the inductance of a single wire bond with a length of 0.3mm and a diameter of 25 $\mu$ m at the input and output ports. In this case no matching circuitry becomes necessary to integrate the MMIC dies into a 50 $\Omega$  environment. The first LNA has been measured up to 28GHz and the second one up to 40GHz. Both the measured input and output return losses and the small signal gain of the P35-5104 are shown in figure 5. The results completely agree with the electrical performance given in the data sheet.

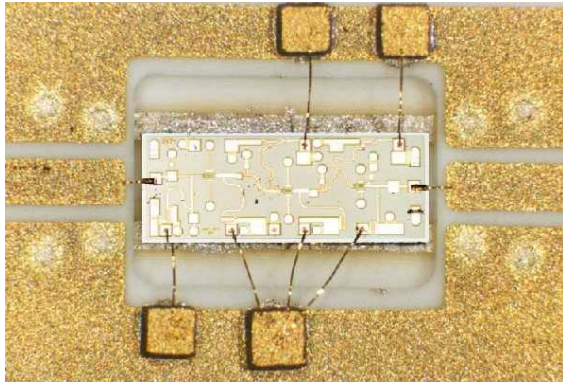


**Fig. 4:** Photo of the GaAs LNA P35-5104 from Marconi Caswell Limited on Ferro A6M tape with screen printed mixed metal conductors (gold and silver)

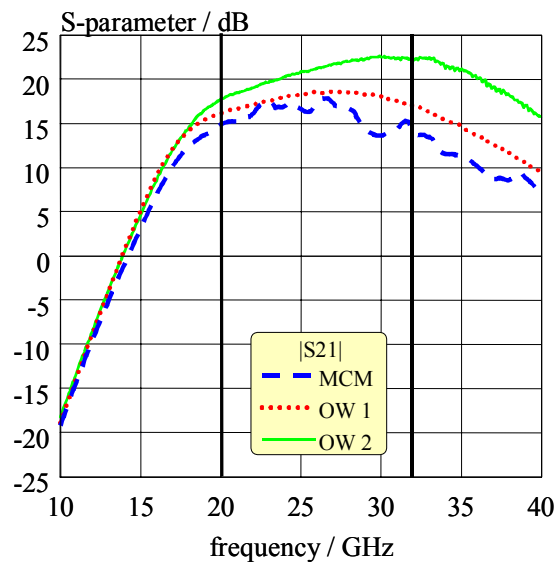


**Fig. 5:** Measured input and output return losses as well as small signal gain of the low noise amplifier P35-5104

The LNA P35-5114 has been measured on-wafer (OW; respectively on-chip) with RF-probes with a GSG pitch distance of 200 $\mu$ m, while the whole LTCC module has been characterised with 450 $\mu$ m probes. These results are presented in the figures 7 and 8, while the S-parameters of OW1 and MCM have been determined with the recommended bias conditions for optimum noise performance and OW2 with a bias setting for an improved gain.



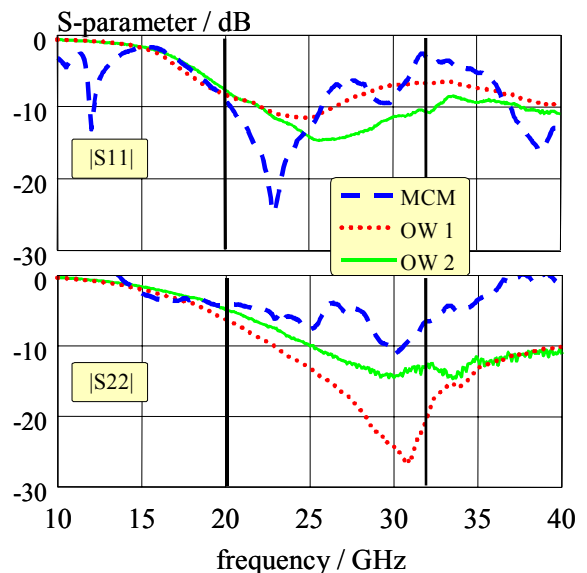
**Fig. 6:** Photo of the GaAs LNA P35-5114 from Marconi Caswell Limited on Ferro A6M tape with screen printed mixed metal conductors (gold and silver)



**Fig. 7:** Measured gain of the LNA P35-5114 (OW1 and OW2: on-wafer with different bias conditions; MCM: LNA on LTCC in CPW environment)

The measured input and output return losses of the LNA in coplanar environment (MCM in figure 8) show some deviations from the on-wafer characterisation. This results from the higher complexity of the coplanar in contrast to the microstrip transition. In the case of the CPW environment the ground of the coplanar top conductors has to be connected to the ground plane of the MMIC, which is on the bottom of the GaAs

substrate. This connection can be realised with filled vias. These vias appear as bright dots on the photo of figure 6. However, such a transformation of an electromagnetic field from a coplanar line (here on LTCC) to the field of a microstrip line (here on GaAs) is much more complicated than the transformation from one microstrip line to another. The CPW-to-MS transition can only be optimised with an electromagnetic field solver and is not only a compensation of the wire inductance. This optimisation has been performed with the software package [6].



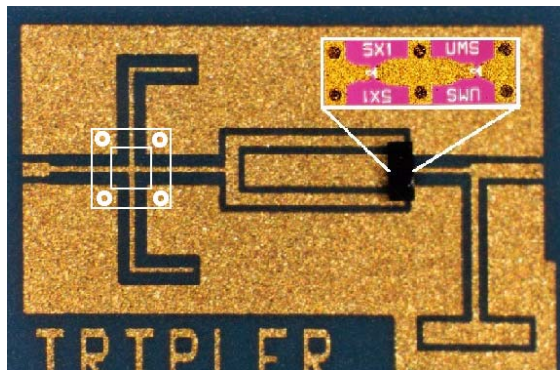
**Fig. 8:** Measured return losses of the LNA

These LTCC tiles have been fabricated by SOREP-ERULEC in France with a high precision in the geometry of the screen printed lines, the cavities as well as the position of the filled vias. These activities are part of the RAMP project.

### Tripler with flip-chip diodes

A common technique for frontends in radio frequencies is to multiply the frequency of the local oscillator source several times. Typical multiplier modules for GHz applications are MMICs fabricated on GaAs. These circuits are more expensive than hybrid solutions and traded with a longer delivery

time. Often, GaAs-MMICs can only be ordered in large quantities, which makes them inapplicable for small companies. An alternative to MMICs are hybrid circuits with GaAs or Si chip devices, which can be mounted with the wire-bond or flip-chip technology to the thin- or thickfilm board. Such an application is presented in this chapter. Instead of using a monolithic tripler a solution on LTCC with a Schottky diode pair has been developed. Wire bonds are reliable in lower frequency bands. Due to the inaccuracy of the length and the shape of the wire, they should be used with care in microwave applications. An alternative are flip-chip devices, where the contact pads can be soldered or pasted on the conductors of the carrier substrate. Figure 9 shows a photo of such a module.



**Fig. 9:** Photo of the tripler on DuPont 951 LTCC with co-fired Fodel™ gold conductor and Schottky diodes from UMS

The carrier material is the DuPont tape 951 with co-fired Fodel™ gold conductor on the top. The tripler circuitry has been designed with coplanar waveguides, where the centre lines and the ground areas are on the same side. This technology requires a ground-to-ground short-circuit around junctions and discontinuities. LTCC offers the advantage to use vias and conductor strips in inner layers to realise these short-circuits. Figure 9 illustrates these vias and the ground-to-ground connections at the cross junction. The left part of the circuit with the two stubs is for the input matching at about 11GHz. In the centre the input signal is split up into the two branches, which are terminated with the dual-diode

chip. The zoomed area in the photo shows the backside of the flip-chip diode. The 6 dark points are the balls for the flip-chip mounting. The right circuitry of the tripler is optimised for the output matching at 33GHz and for filtering the first harmonic at 11GHz. The evaluation of the tripler shows an optimum input power of 13dBm with a conversion loss of 18dB.

### Summary

Three different integration techniques for MMICs and chip devices have been tested on multilayer LTCC substrates for microwave applications: MMIC mounting on top and in cavities of LTCC connected with wire bonds as well as flip-chip mounting of a dual-diode. Modules with these techniques have been designed, fabricated and evaluated. The advantages and the difficulties have been pointed out. It can be summarised, that the examples show the capability of the multilayer LTCC technology (including embedded monolithic circuits and chips) for industrial microwave applications.

### Acknowledgements

The authors wish to thank the European Commission for supporting the RAMP [1] activities, as well as the other partners of the project consortium for the excellent co-operation, the helpful discussions and ideas as well as their competent advising in solving several problems. Special acknowledgement is given to Sorep-Erulec in France. They have fabricated the LTCC for the LNAs with excellent properties.

Thanks are also given to the German ministry for education and research (BMBF) for supporting the 4M [2] project, which has been finished in October 1999. The LTCC for the power amplifier and the tripler has been fabricated by VIA electronic in Germany and the Fodel has been processed by DuPont in Great Britain with great success.

## References

- [1] *4M*: “Multifunctional Micro- & MM-Wave Modules”, a German BMBF project managed by VDI/VDE.
- [2] *RAMP*: “Rapid Manufacture of Microwave and Power Modules”, a BriteEuram project (BE-97-4883).
- [3] W. Simon, R. Kulke, A. Wien, I. Wolff, S. Baker, R. Powell, M. Harrison, “Design of Passive Components for K-Band Communication Modules in LTCC Environment”, IMAPS Symposium, pp. 183-188, Chicago, October 1999.
- [4] R. Kulke, M. Rittweger, W. Simon, A. Wien, I. Wolff, „High Resolution Coplanar Structures on Multilayer LTCC for Applications up to 40 GHz“, IMAPS Symposium, pp. 79-83, Chicago, October 1999.
- [5] W. Simon, R. Kulke, A. Wien, M. Rittweger, I. Wolff, A. Girard, J.-P. Bertinet, „Interconnects and transitions in Multilayer LTCC Multichip Modules for 24 GHz ISM-Band Applications“, accepted paper for the IEEE International Microwave Symposium, Boston, June 2000.
- [6] IMST GmbH, "User and Reference Manual for the 3D EM Time Domain Simulator Empire", <http://www.imst.de/microw/producs/empire/downloads.html>, February 1999.
- [7] "DECT faces multimedia challenge", Focus on Communication Technology, Microwave Engineering Europe, August/September 1997.
- [8] M. D. O'Hearn, "Realisierung eines VCO in LTCC-Technik", HF-Report, September/Okttober 3/97, pp. 53-56.
- [9] R. Brown, "LTCC-Bringing Functional Integration to RF & Microwave Products", National Semiconductor Corp., <http://207.82.57.10/appinfo/lccc/>.
- [10] M. O'Hearn, "Designing a frequency synthesizer module using low-temperature co-fired ceramic", RF Design, November 1996.
- [11] M. Oppermann, "Multichip-Modules (MCMs) for Micro- and Millimeter-Wave Applications - a Challenge ?", International Conference on Multichip Modules and High Density Packaging, MCM, pp. 297 – 303, Denver 1998.